

Pneumatic cylinder

TOSS[®]

Type B, D2R

double-acting

Linear Ball Slide

Ø 20/25/32

40 mm

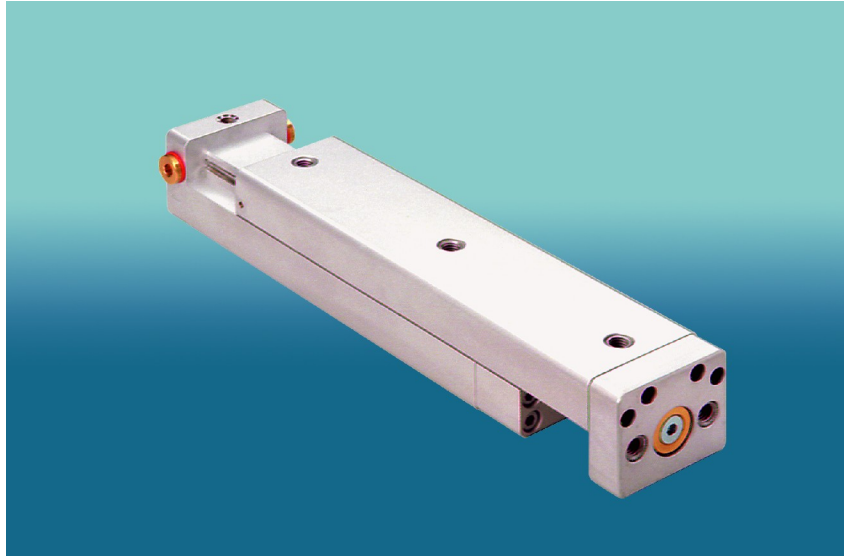

Includes adjustable end position cushioning on both sides.

Technical data:

Type	20 - B, D2R	25 - B, D2R	32 - B, D2R	40 - B, D2R
Design type	Pneumatic cylinder with linear ball guide and adjustable end position cushioning on both sides			
Stroke length [mm]	80, 100, 125, 160, 200			
Fitting position	any (provided that extended position can always be attained)			
Adm. temperature range [°C]	-10 to +70			
Medium	Filtered, oiled or non-oiled compressed-air (min. fineness 40 µm)			
Compressed-air supply	Front, lateral or combi-type			
Compressed-air [bar]	min. 2 ... max. 6			
Materials	Base body, upper part, mounting plate, cover, piston plate: Al Guides: 100 Cr 6, piston rod: Ck 45 SL f7 Setting screws: Ms 58 Pistons, seals: NBR, cylinder barrel: Ms 63			

Weights: (gramme)

Piston - Ø [mm]	Stroke length [mm]				
	80	100	125	160	200
20	780	880	1080	1320	1580
25	1380	1580	1880	2240	2640
32	1780	2080	2440	2880	3480
40	2560	2960	3360	4000	4700

Delivery time on request

Pneumatic cylinder



Type B, D2R

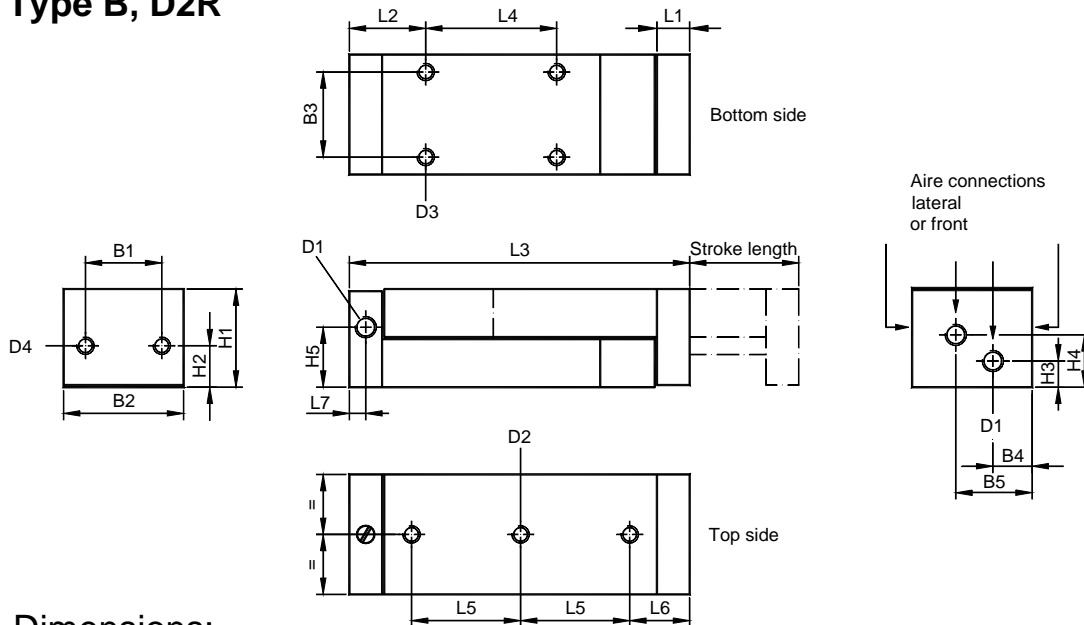

Dimensions:

Piston \varnothing [mm]	Piston rod \varnothing [mm]	B1 [mm]	B2 [mm]	B3 [mm]	B4 [mm]	B5 [mm]	D1	D2/depth [mm]	D3/depth [mm]	D4/depth [mm]	H1 [mm]	H2 [mm]	H3 [mm]	H4 [mm]	H5 [mm]	L1 [mm]
20	8	30	40	30	12,5	24,5	M5	M6/8,0	M6/14	M6/11,5	39,5	15,5	8	20	8,8	12
25	10	35	55	39	17,5	34,75	G1/8	M8/7,5	M8/16	M8/10,5	45	19,0	11	24	28	15
32	12	45	65	49	20	40,5	G1/8	M8/7,5	M8/18	M8/10,5	50	20,0	10,8	28,3	31,3	15
40	15	50	70	54	22	44,5	G1/4	M8/10,5	M8/18	M8/10,5	65	27,0	14	36,5	40,5	20

Piston - \varnothing [mm]		Stroke length [mm]				
		80	100	125	160	200
20	L2	27	27	27	27	27
	L3	175	200	245	305	360
	L4	2 x 47,5	2 x 60	2 x 82,5	2 x 112,5	2 x 140
	L5	3 x 42	3 x 50	3 x 65	3 x 85	4 x 78
	L6	24,0	24,5	24,5	24,5	23,5
	L7	6	6	6	6	6
25	L2	35	35	35	35	35
	L3	211	246	286	341	411
	L4	115	2 x 75	2 x 95	2 x 122,5	2 x 157,5
	L5	2 x 78	2 x 95	3 x 77	3 x 95	3 x 115
	L6	27,0	27,5	27,0	27,5	32,5
	L7	7,5	7,5	7,5	7,5	7,5
32	L2	35	35	35	35	35
	L3	211	246	286	341	411
	L4	110	2 x 72,5	2 x 92,5	2 x 120	2 x 155
	L5	2 x 78	2 x 95	3 x 77	3 x 95	3 x 115
	L6	27,0	27,5	27,0	27,5	32,5
	L7	7,5	7,5	7,5	7,5	7,5
40	L2	40	40	40	40	40
	L3	221	256	296	351	421
	L4	2 x 55	2 x 72,5	2 x 92,5	2 x 120	2 x 155
	L5	2 x 78	2 x 95	3 x 77	3 x 95	3 x 115
	L6	32,0	32,5	32,0	32,5	37,5
	L7	10	10	10	10	10

Pneumatic cylinder

Admissible stress

Type B, D2R

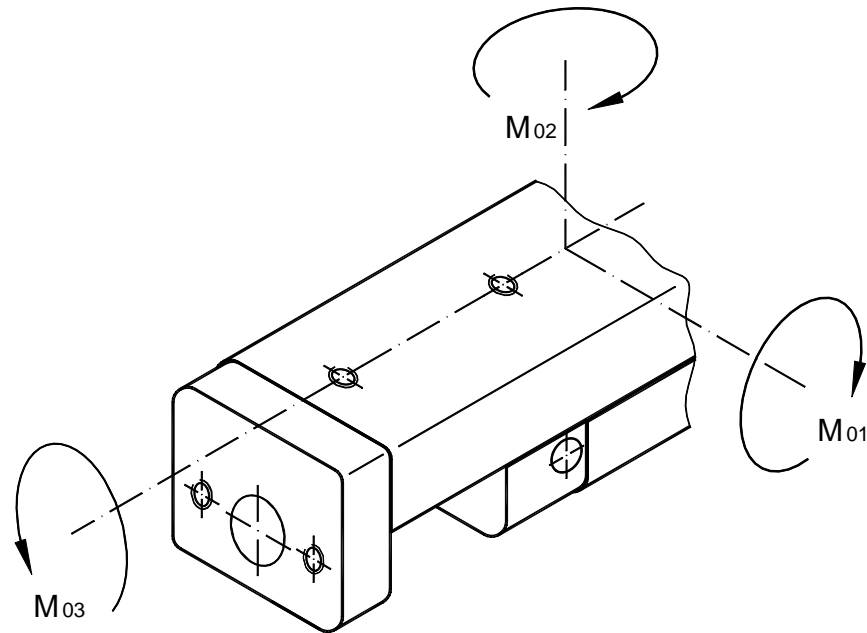

Longitudinal torque	Lateral torque	Transverse torque
$F_{01} \leq \frac{M_{01 \text{ zul.}}}{L_1 + A}$	$F_{02} \leq \frac{M_{02 \text{ zul.}}}{L_2 + A}$	$F_{03} \leq \frac{M_{03 \text{ zul.}}}{L_3 + B}$
$F_{01} \leq \frac{M_{01 \text{ zul.}}}{L_1 + C}$	$F_{02} \leq \frac{M_{02 \text{ zul.}}}{L_2 + B}$	$F_{03} \leq \frac{M_{03 \text{ zul.}}}{L_3 + C}$

Admissible stress

Pneumatic cylinder



Stroke length [mm]	80		100		125		160		200	
Ø / Type	M1/M2 Nm	M3 Nm	M1/M2 Nm	M3 Nm	M1/M2 Nm	M3 Nm	M1/M2 Nm	M3 Nm	M1/M2 Nm	M3 Nm
20 - B, D2R	2,0	1,16	3,0	1,74	3,6	1,74	5,0	1,74	6,3	1,74
25 - B, D2R	6,1	2,65	7,1	3,04	8,6	3,04	10,0	3,04	12,7	3,04
32 - B, D2R	6,9	4,56	9,2	5,90	10,8	5,90	13,9	5,90	17,6	5,90
40 - B, D2R	6,9	4,69	8,5	5,63	10,2	5,63	13,3	5,63	17,0	5,63

Correction factors:

Ø / Type	Stroke length	A	B	C
20 - B, D2R	80	92,7	19,75	13,6
	100	111,1		
	125	127,8		
	160	157,9		
	200	188,4		

Ø / Type	Stroke length	A	B	C
25 - B, D2R	80	112,2	27,25	16,0
	100	127,4		
	125	152,2		
	160	173,0		
	200	208,5		

Ø / Type	Stroke length	A	B	C
32 - B, D2R	80	110,8	32,25	17,7
	100	130,1		
	125	148,8		
	160	178,7		
	200	214,2		

Ø / Type	Stroke length	A	B	C
40 - B, D2R	80	115,8	34,75	20,8
	100	132,0		
	125	150,7		
	160	180,6		
	200	216,1		

Example of calculation:

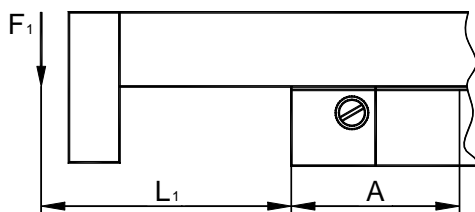

Stress - longitudinal torque M_1

Given qty: 32 - B, D2R with a stroke length of 125 mm
 Lever arm $L_1 = 50 \text{ mm} = 0,05 \text{ m}$
 Longitudinal torque $M_1 = 10,8 \text{ Nm}$
 Correction factor $A = 148,8 \text{ mm} = 0,1488 \text{ m}$

$$\text{Required qty: } F_1 \leq \frac{M_1}{L_1 + A} = \frac{10,8 \text{ Nm}}{0,05 \text{ m} + 0,1488 \text{ m}} = 54,3 \text{ N}$$