

Start-up - Maintenance - Repair

All TOSS pneumatic cylinders are equipped with a precision guide. Impacts and the application of high torque values for loads as well as scratches on the slideways or the piston rods should be avoided, as they may lead to malfunction or leakage. The maximum piston speed of 1 m/s may not be exceeded, as otherwise the guides could be damaged.

The design types A and B should always be moved to their extended limit position in order to avoid uneven displacement of the two ball rows during intermediate strokes.

The TOSS pneumatic cylinders have a lifetime lubrication and require correctly treated compressed-air. When working under difficult operating conditions (heat, dust, humidity) it is recommended to lubricate the ball guides periodically. The pneumatic cylinder type C is provided with a lubrication system. Depending on the field of application, this lubrication system should be used at regular intervals to lubricate the ball guide (use instructions see pneumatic cylinder type C). Of course, the special grease for our pneumatic cylinders and the appropriate repair sets can be ordered from us (see service set).

The instructions and limit values of the specified temperatures, pressures, masses and forces must be complied with in order to ensure correct functioning.

Mounting instructions!

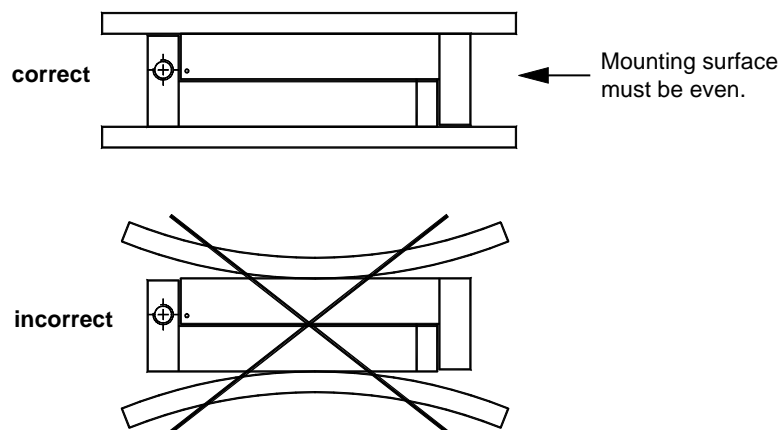

Note:

If the cylinders are operated with oiled compressed air (oil content $> 10 \text{ mg/m}^3$, approx. 0.5 oil drops/1000 l air), take care that they are always operated with oiled compressed air in future, as the basic lubrication will be washed out by additional oiling.

Pneumatic cylinder

Service-set

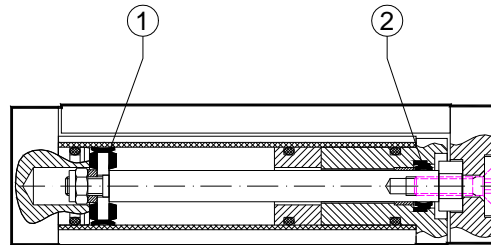

Pneumatic cylinder type B und C (size $\varnothing 16 - \varnothing 40$)
 1 piston assembly
 2 scraper rings

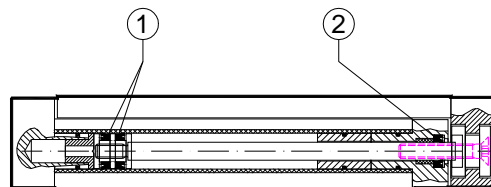

Pneumatic cylinder Typ A (size $\varnothing 10 - \varnothing 40$)
 Pneumatic cylinder Typ B (only size $\varnothing 8 - \varnothing 10$)
 Pneumatic cylinder Typ C (only size $\varnothing 10$)
 1 piston seals
 2 scraper ring

Type	Diameter [mm]	Article no.
A	10	38510039
	16	38510043
	20	38510040
	25	38510060
	32	38510054
	40	38510141
B	8	38510142
B and C	10	38510143
	16	38510144
	20	38510145
	25	38510146
	32	38510147
	40	38510148

Pneumatic cylinder

Order data for pneumatic cylinders

Example of an order:

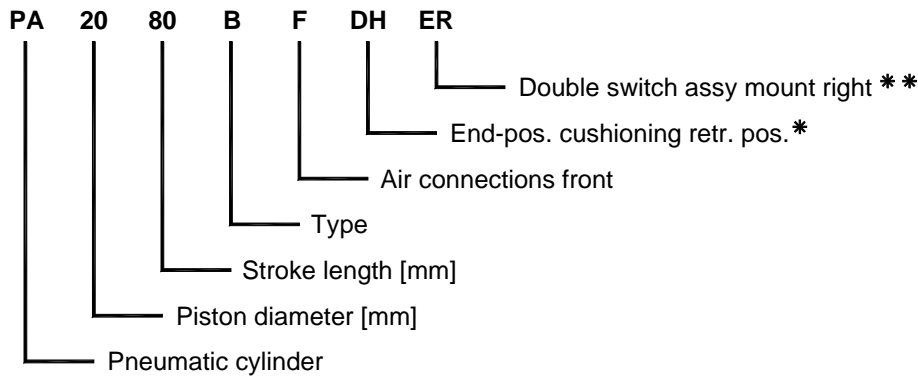

* for orders with end-position cushioning see following table.

Type	End-position cushioning		
	Two-sided (D2)	Retr. pos. (DH)	Ausgef. Pos. (DV)
B	as from \varnothing 20/stroke length 80	As from \varnothing 20/stroke length 10	as from \varnothing 20/stroke length 80
C	as from \varnothing 20/stroke length 50	as from \varnothing 20/stroke length 25	as from \varnothing 20/stroke length 50

** for orders with limit switches (inductive) see following table.

Type	Double switch assy. Mounting pos. right	Double switch assy. Mounting pos. left	Separate switch assy. Mounting pos. right, retr. pos.	Separate switch assy. Mounting pos. left, retr. pos.	Separate switch assy. Mounting pos. right, ext. pos.	Separate switch assy. Mounting pos. left ext. pos.
A/B Piston \varnothing 10-40 Stroke length 10-200	(ER)	(EL)	(EREP)	(ELEP)	(ERAP)	(ELAP)

Separate switches are mounted from a stroke length of 125 mm upwards!

** for orders with switch rails see following table.

Type	Switch rail assy. Mounting pos. right / left	Switch rail assy. Mounting pos. right	Switch rail assy. Mounting pos. left
A/B Piston \varnothing 8-40 Stroke leng. 10-200	(CSRL)	(CSR)	(CSL)

Electrical switch for pneumatic cylinder with mounted switch rails or integrated sensor grooves art. no. **38510022**

Pneumatic cylinder



Effective surfaces – (theoretical forces)

Cylinder ∅ [mm]	Piston rod- ∅ [mm]	Piston surfaces A [cm ²]		Piston forces (theoretical values) F [N]									
				2 bar		3 bar		4 bar		5 bar		6 bar	
				VH	RH	VH	RH	VH	RH	VH	RH	VH	RH
8	4	0,5	0,37	10	7,5	15	11	20	15	25	19	30	22
10	5	0,8	0,59	15	11,8	24	18	32	24	40	30	48	35
12	5	1,1	0,9	22	18	33	27	44	36	55	45	66	54
16	8	2,0	1,5	40	30	60	45	80	60	100	75	120	90
20	8	3,1	2,6	63	52	93	78	124	104	155	130	186	156
25	10	4,9	4,1	98	82	147	123	196	164	245	205	294	246
32	12	8,0	6,9	160	138	240	207	320	276	400	345	480	414
40	15	12,6	10,8	251	216	378	324	504	432	630	540	756	648
50	16	19,6	17,6	391	352	588	528	784	704	980	880	1176	1056
63	20	31,1	28,0	623	560	933	840	1244	1120	1555	1400	1866	1680
80	25	50,2	45,3	1005	906	1506	1359	2008	1812	2510	2265	3012	2718

$$F = A \times p$$

Forward stroke (VH) Return stroke (RH)