

Type SEK

Adjustable
Slideway

Design size
25

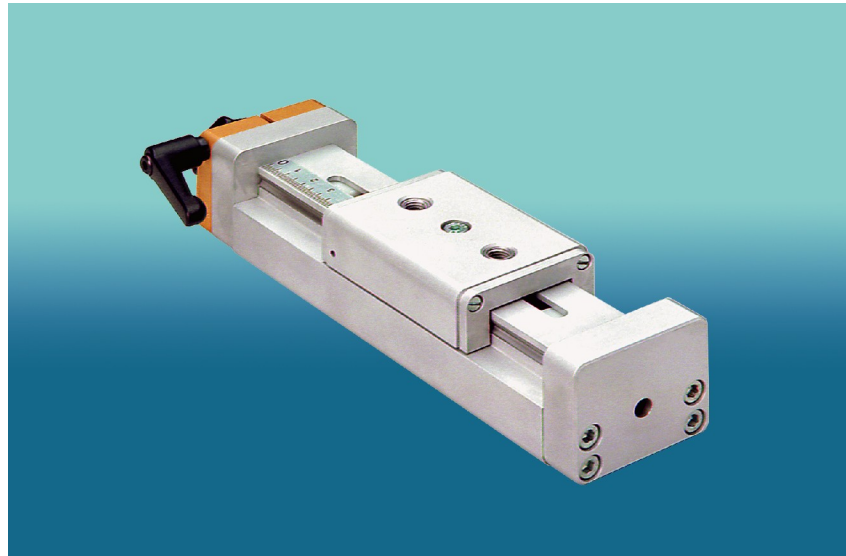

For machines frequently requiring adjustments, size changes, positioning, etc. (e.g. packaging machines), TOSS – Pneumatic produces special manually-controlled linear actuators. These actuators are supplied with a clamping plate.

Technical data:

Type	25 - SEK		
Design type	Slideway		
Positioning distance [mm]	90, 220, 290		
Pitch of threaded spindle	1,5		
Spindle dimensions	M10 - LH		
Adm. temperature range [°C]	-10 to +70		
Mounting position	Any		
Materials	Base body, upper part, cover, plate: Al Protecting tube: Ms 63, tube nut, spindle nut, clamping plate: Ms58 Threaded spindle: VA		
Weights [gramme]	1220	1620	1820

Actuators



Type SEK

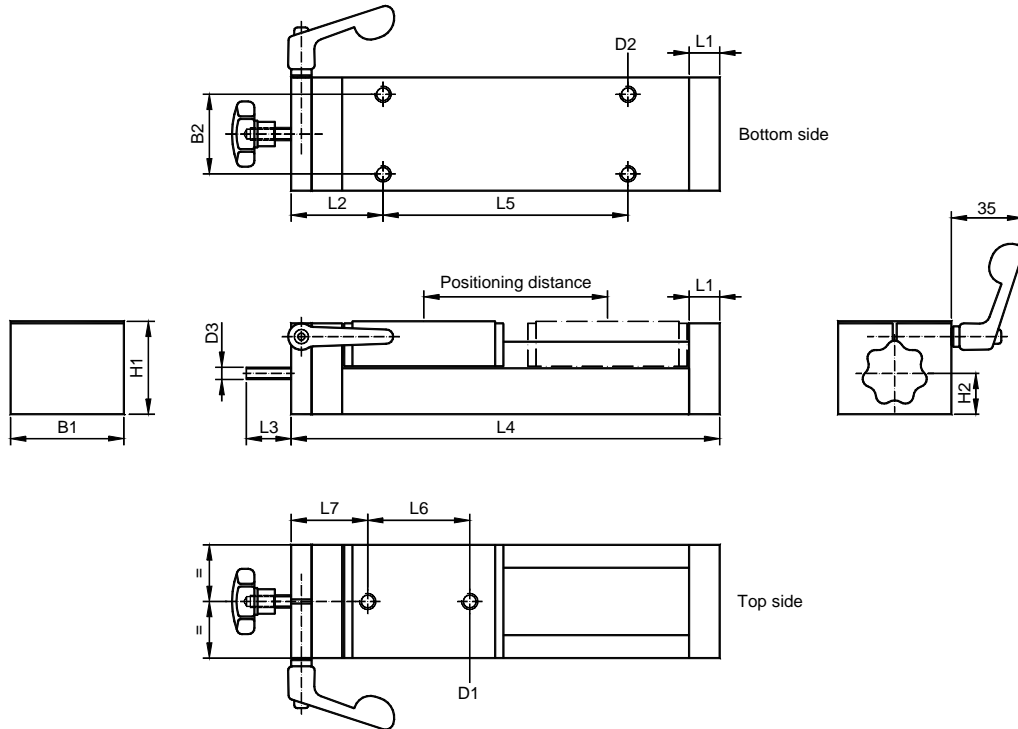

Dimensions:

Size	Pitch spindle [mm]	B1 [mm]	B2 [mm]	D1/depth [mm]	D2/depth [mm]	D3 [mm]	H1 [mm]	H2 [mm]	L1 [mm]	L2 [mm]	L3 [mm]
25	1,5	55,5	39	M8/7,5	M8/16	∅ 6	45,5	19,0	15	45	17

Size	Positioning distance [mm]			
	90	220	290	
25	L4	210	340	410
	L5	130	2 x 130	2 x 165
	L6	45	45	45
	L7	42,5	42,5	42,5