

# Linear guides

## Type LF

Linear Ball Slide

Design sizes  
10/16



Linear guide for low to medium loads.

### Technical data:

Type	10 - LF	16 - LF
Design type	Linear ball guide	
Stroke length [mm]	10, 25, 50, 80, 100, 125, 160, 200 (on both sides)	
Mounting position	Any	
Adm. temperature range [°C]	-10 to +70	
Ball - Ø [mm]	3	
Materials	Base body, upper part, cover: Al Guides: Steel rods, hardened and ground 100 Cr 6	
<b>Attention: The stroke must be limited externally!</b>		

### Weights: (gramme)

Size	Stroke length [mm]							
	2 x 10	2 x 25	2 x 50	2 x 80	2 x 100	2 x 125	2 x 160	2 x 200
10	120	150	230	310	360	450	570	680
16	165	200	300	405	460	580	730	860

Delivery time on request

# Linear guides



## Type LF

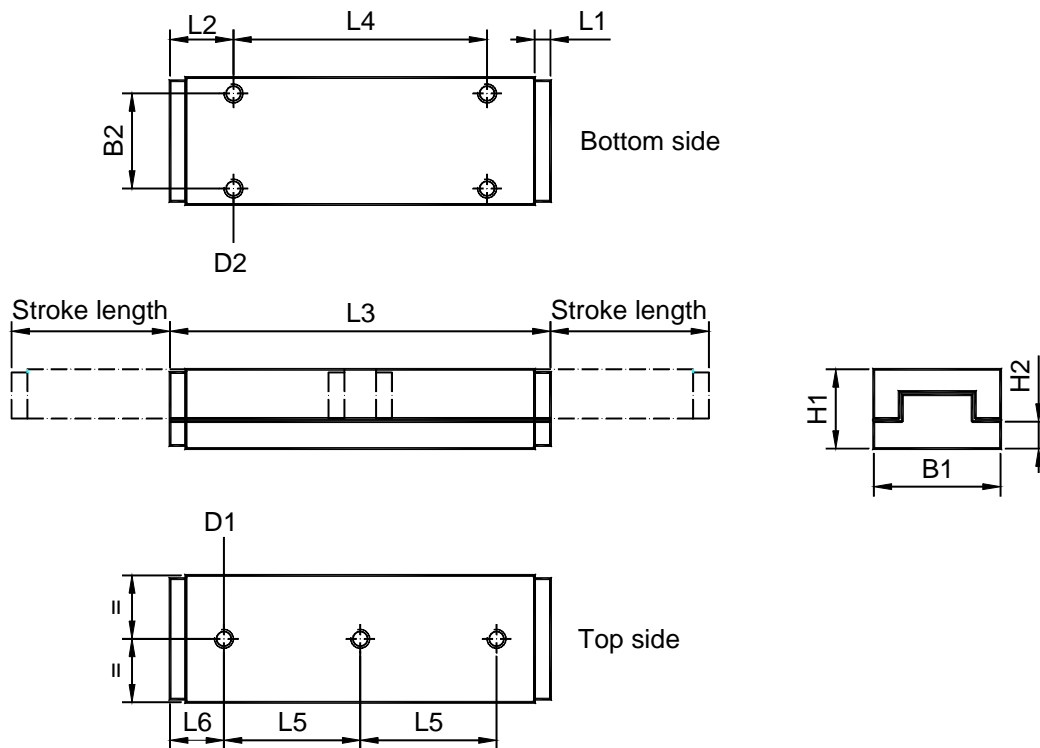

### Dimensions:

Size	B1 [mm]	B2 [mm]	D1/depth [mm]	D2/depth [mm]	H1 [mm]	H2 [mm]	L1 [mm]	L2 [mm]
10	35	25	M6/5,0	M5/6,0	22	6,5	5	20
16	40	30	M6/5,5	M6/8,0	25	8,5	5	20

Size		Stroke length [mm]							
		2 x 10	2 x 25	2 x 50	2 x 80	2 x 100	2 x 125	2 x 160	2 x 200
10 / 16	L3	65	80	120	160	185	230	290	345
	L4	25	40	80	2 x 60	2 x 72,5	2 x 95	2 x 125	2 x 152,5
	L5	31	2 x 23	2 x 43	3 x 42	3 x 50	3 x 65	3 x 85	4 x 78
	L6	17	17	17	17	17,5	17,5	17,5	16,5

# Linear guides

Admissible stress

## Type LF

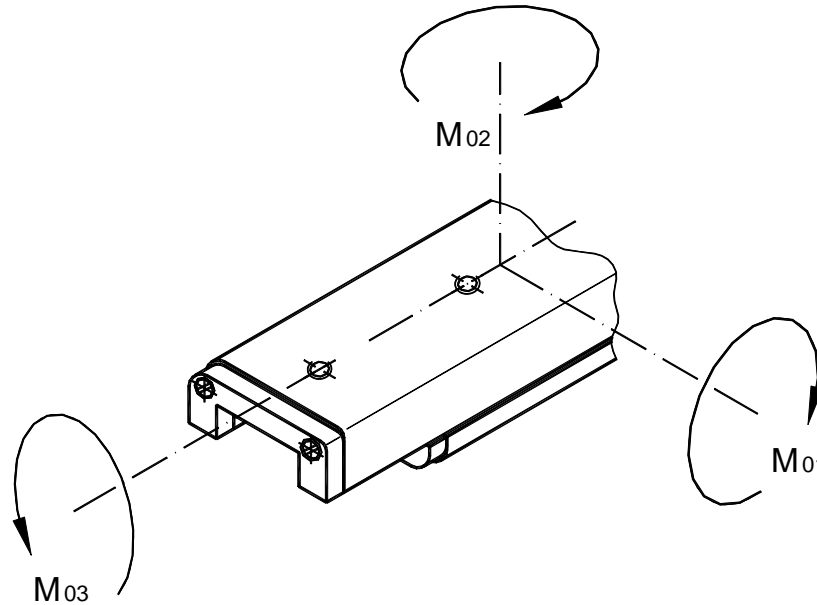

Longitudinal torque	Lateral torque	Transverse torque
$F_{01} \leq \frac{M_{01 \text{ zul.}}}{L_1 + A}$	$F_{02} \leq \frac{M_{02 \text{ zul.}}}{L_2 + A}$	$F_{03} \leq \frac{M_{03 \text{ zul.}}}{L_3 + B}$
$F_{01} \leq \frac{M_{01 \text{ zul.}}}{L_1 + C}$	$F_{02} \leq \frac{M_{02 \text{ zul.}}}{L_2 + B}$	$F_{03} \leq \frac{M_{03 \text{ zul.}}}{L_3 + C}$

## Linear guides

### Admissible stress

Stroke length [mm]	10		25		50		80		100		125	
Type	M1/M2 Nm	M3 Nm	M1/M2 Nm	M3 Nm	M1/M2 Nm	M3 Nm	M1/M2 Nm	M3 Nm	M1/M2 Nm	M3 Nm	M1/M2 Nm	M3 Nm
10 - LF	3,80	0,98	3,80	0,98	5,00	1,27	6,40	1,47	7,40	1,56	8,30	1,56
16 - LF	4,20	1,08	4,20	1,08	5,50	1,40	7,04	1,62	8,14	1,72	9,13	1,72

Stroke length [mm]	160		200	
Type	M1/M2 Nm	M3 Nm	M1/M2 Nm	M3 Nm
10 - LF	10,80	1,56	12,70	1,56
16 - LF	11,90	1,72	14,00	1,72

### Correction factors:

Type	Stroke length [mm]	A [mm]	B [mm]	C [mm]
10 - LF	10	54	17	10,4
	25	54		
	50	82,5		
	80	110		
	100	128,5		
	125	149,5		
	160	192		
	200	229		

Type	Stroke length [mm]	A [mm]	B [mm]	C [mm]
16 - LF	10	54	19,5	11,5
	25	54		
	50	82,5		
	80	110		
	100	128,5		
	125	149,5		
	160	192		
	200	229		

### Example of calculation:

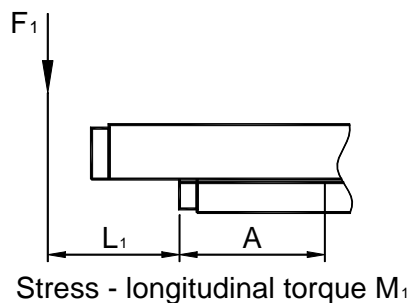

Given qty: 10 - LF with a stroke length of 100 mm  
 Lever arm  $L_1 = 50 \text{ mm} = 0,05 \text{ m}$   
 Longitudinal torque  $M_1 = 7,4 \text{ Nm}$   
 Correction factor  $A = 128,5 \text{ mm} = 0,1285 \text{ m}$

$$\text{Required qty: } F_1 \leq \frac{M_1}{L_1 + A} = \frac{7,4 \text{ Nm}}{0,05 \text{ m} + 0,1285 \text{ m}} = 41,5 \text{ N}$$